



# SERIE XP

# 3.1.2.3.

## Pompa ad Ingranaggi Gear Pump

CODICE DI ORDINAZIONE - DECODING

3.1.2.3 . XXX . X . 0 . 0 . 0

UNI  
21-222

- XP 15
- XP 22
- XP 36
- XP 43
- XP 57
- XP 65
- XP 75
- XP 83
- XP 102

ALLESTIMENTI SPECIALI/SPECIAL OPTIONS  
0 = NON RICHIESTO/STANDARD OPTION

ROTAZIONE/ROTATION  
1 = SINISTRO/ANTICLOCKWISE  
2 = DESTRO/CLOCKWISE

CILINDRATA/DISPLACEMENT

CODICE BASE/BASIC CODE

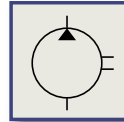

### CARATTERISTICHE E DATI TECNICI - SPECIFICATIONS AND TECHNICAL DATA

TIPO TYPE	CODICE CODE	CILINDRATA DISPLACEMENT cm <sup>3</sup> /rev.	A mm	B mm	C	D mm	PESO WEIGHT kg
XP 15	3.1.2.3.015.X.0.0.0	15	139	76	3/4" G	116	6.7
XP 22	3.1.2.3.022.X.0.0.0	22	144	76	3/4" G	116	7.2
XP 36	3.1.2.3.036.X.0.0.0	36	154	76	3/4" G	116	8.1
XP 43	3.1.2.3.043.X.0.0.0	43	159	90.5	1" G	116	8.6
XP 57	3.1.2.3.057.X.0.0.0	57	169	90.5	1" G	116	9.5
XP 65	3.1.2.3.065.X.0.0.0	65	174	90.5	1" G	116	9.9
XP 75	3.1.2.3.075.X.0.0.0	75	182	90.5	1" G	116	10.6
XP 83	3.1.2.3.083.X.0.0.0	83	189	90.5	1" G	116	11.2
XP 102	3.1.2.3.102.X.0.0.0	102	201	99.5	1" 1/4 G	120	12.2

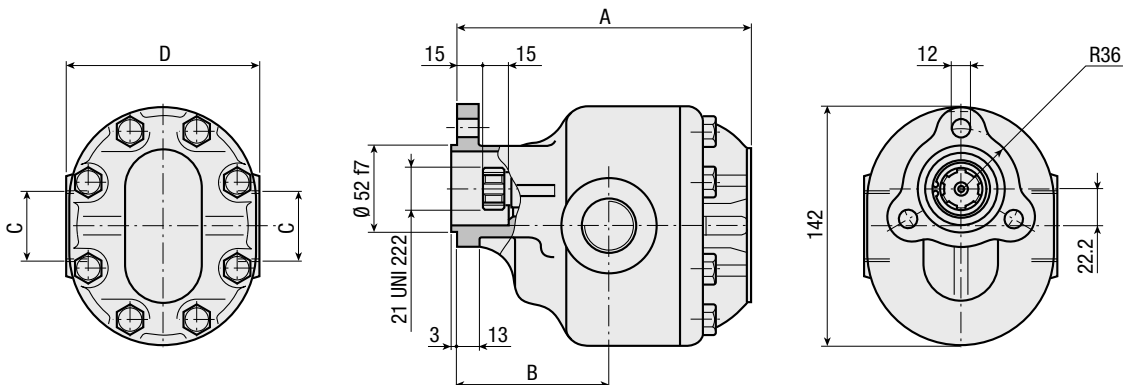

## DATI TECNICI - TECHNICAL DATA

### ESEMPIO CICLI LAVORO - EXAMPLE OF WORKING CYCLES

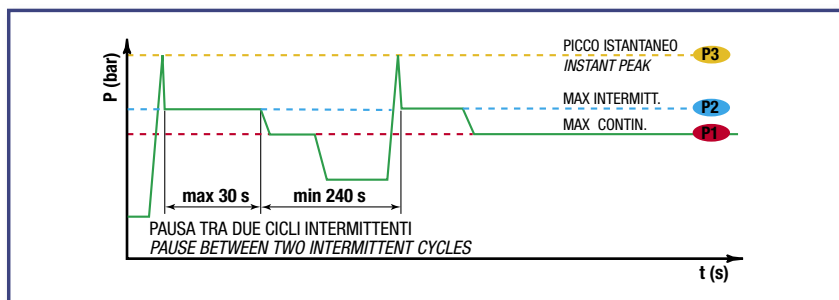

Pressione d'aspirazione: Inlet pressure:	0.7 ÷ 1.5 bar (assoluti/absolute)
Campo viscosità lavoro: Operating viscosity range:	12 ÷ 100 cSt
Temperatura fluido °C (t): Fluid temperature °C (t):	-10° + 80° C

Pressione Lavoro Working Press. P2	Contaminazione - Contamination		Filtro - Filter βx = 75
	NAS 1638	ISO 4406	
≤ 200 bar	12	21/18	40 μm
≥ 200 bar	11	20/17	25 μm

◀ **FILTRAZIONE CONSIGLIATA (ritorno o mandata)**  
**RECOMMENDED FILTERING (return or outlet)**

TIPO - TYPE			XP 15	XP 22	XP 36	XP 43	XP 57	XP 65	XP 75	XP 83	XP 102
Cilindrata Displacement	Vg	cm <sup>3</sup> /n cm <sup>3</sup> /rev.	15	22	36	43	57	65	75	83	102
Pressione massima continua Max continuous operating pressure	P1	bar	315	305	300	280	260	240	220	210	180
Pressione massima intermittente Max intermitt. operating pressure (max 30 s)	P2		340	330	325	305	285	265	240	230	200
Pressione massima di picco Max peak pressure (≤ 0.1 s)	P3		450	450	450	400	380	330	320	300	250
Velocità massima intermittente Max intermittent speed (P ≤ 20 bar)	n3	n/min r.p.m.	3000	3000	3000	3000	3000	3000	3000	3000	2500
Velocità massima continua Max continuous speed (≤ P1)	n1		2500	2500	2500	2500	2500	2500	2500	2500	2000
Velocità minima intermittente Min intermittent speed (≤ P2 x 0.5) (max 30 s)	n4		450	450	350	350	300	300	300	300	300

POTENZA ASSORBITA - ABSORBED POWER

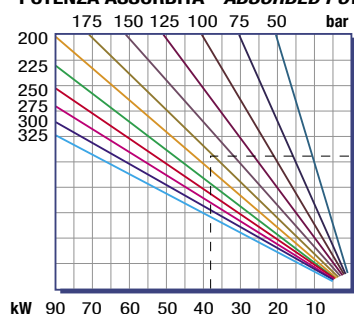

PORTATA - CAPACITY

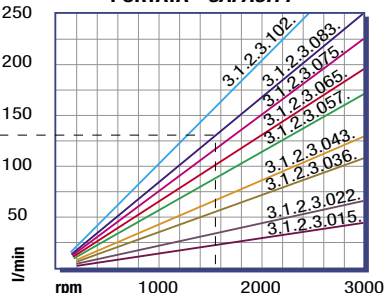

RILIEVI ESEGUITI CON OLIO  
ISO VG 46 A 50° C (ν=30 cSt)  
THE ABOVE SPECIFICATIONS  
REFER TO OIL TYPE ISO  
VG 46 AT 50° C (ν=30 cSt)

## DIAGRAMMI - DIAGRAMS

RENDIMENTO VOLUMETRICO - VOLUMETRIC EFFICIENCY

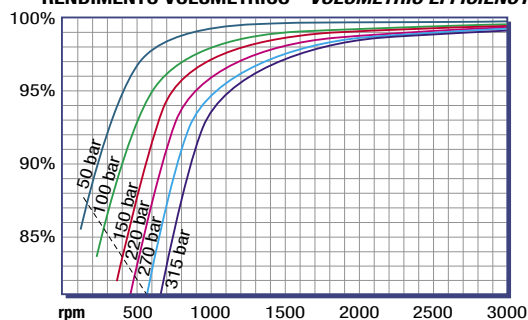

COPPIA ASSORBITA - INPUT TORQUE

