

SERIE EOS

3.1.7.0.

CODICE DI ORDINAZIONE - DECODING

3.1.7.0 . XXX . 2 . X . 00

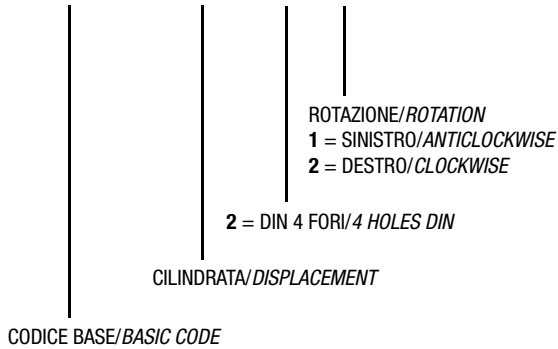

DIN
5 4 6 2
SE

EOS 34
EOS 47
EOS 64
EOS 84
EOS 108

Pompa a Pistoni Piston Pump

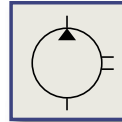

CARATTERISTICHE E DATI TECNICI - SPECIFICATIONS AND TECHNICAL DATA

TIPO - TYPE			EOS 34	EOS 47	EOS 64	EOS 84	EOS 108
Cilindrata Displacement	Vg	cm ³ /n cm ³ /rev.	34.60	47.39	64.08	84.38	107.70
Pressione massima Max operating pressure	P1	bar	450	450	450	400	350
Pressione massima di picco Max peak pressure (≤ 0.1 s)	P3		500	500	500	450	400
Velocità massima intermittente Max intermittent speed (P ≤ 30 bar)	n3	n/min r.p.m.	3000	2600	2500	2400	2200
Velocità massima continua Max continuous speed (≤ P1)	n1		2400	2100	2000	1900	1700
Velocità minima intermittente Min intermittent speed (≤ P2 x 0.5) (max 30 s)	n4		300				
Pressione in aspirazione (assoluta) Suction pressure (absolute)	P	bar	0.7 ÷ 1.5				
Campo di viscosità lavoro Operating viscosity range	√	cST	9 ÷ 75				
Campo di viscosità ottimale Optimal viscosity range	√		15 ÷ 46				
Massima viscosità avviamento Start up max viscosity	√		1000				
Temperatura fluido °C (t) Fluid temperature °C (t)	t	°C	-25° ÷ 80°				

DIMENSIONI - DIMENSIONS

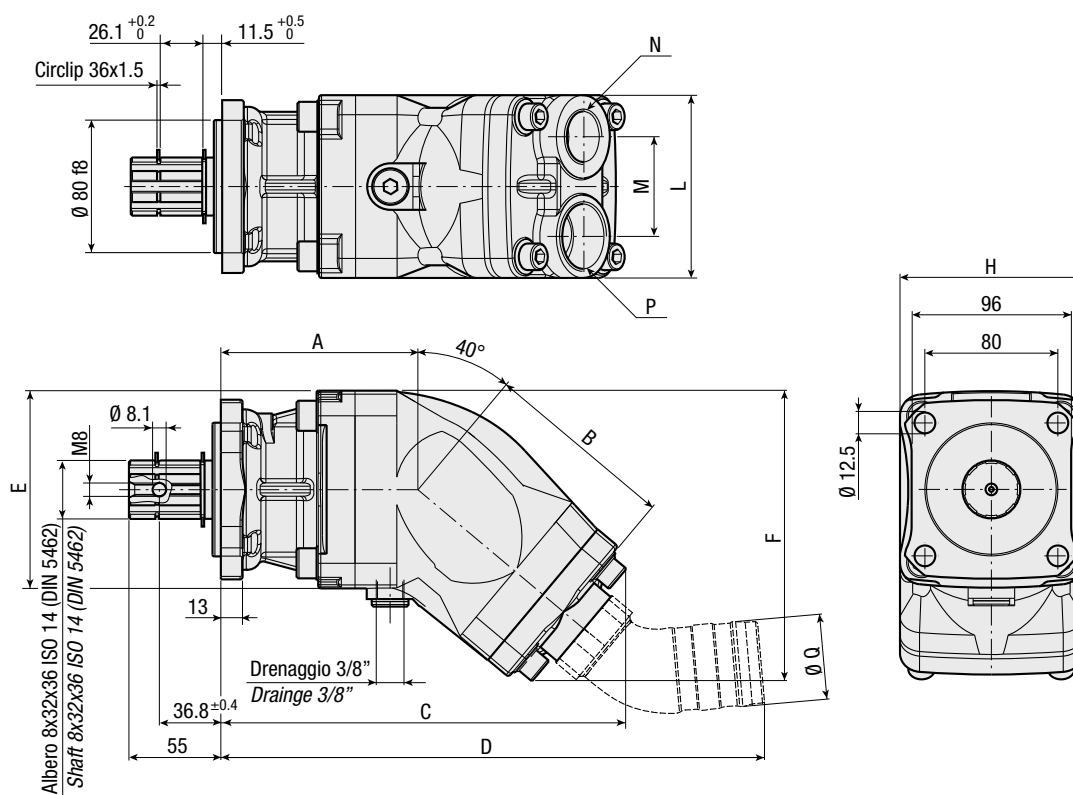

CARATTERISTICHE E DATI TECNICI - SPECIFICATIONS AND TECHNICAL DATA

TIPO TYPE	CODICE CODE	A mm	B mm	C mm	D mm	E mm	F mm	G mm	H mm	L mm	M mm	MANDATA OUTLET N	ASPIRAZIONE INLET		PESO WEIGHT kg
													P	Q mm	
EOS 34	3.1.7.0.034.2.X.00	109	113	220	308	107	157	107.5	102	95	46	3/4" G	1" G	45	10.5
EOS 47	3.1.7.0.047.2.X.00	109	113	220	308	107	157	107.5	102	95	46	3/4" G	1" G	45	10.5
EOS 64	3.1.7.0.064.2.X.00	118	128	240	328	118	173	107.5	110	110	60	1" G	1" 1/4 G	51	13.5
EOS 84	3.1.7.0.084.2.X.00	118	128	240	328	118	173	107.5	110	110	60	1" G	1" 1/4 G	51	13.5
EOS 108	3.1.7.0.108.2.X.00	118	128	240	328	118	173	107.5	110	110	60	1" G	1" 1/4 G	51	13.5



SERIE EOS 3.1.7.0.

DIN
5 4 6 2
SE

EOS 34
EOS 47
EOS 64
EOS 84
EOS 108

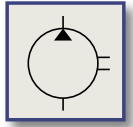

DIAGRAMMI - DIAGRAMS

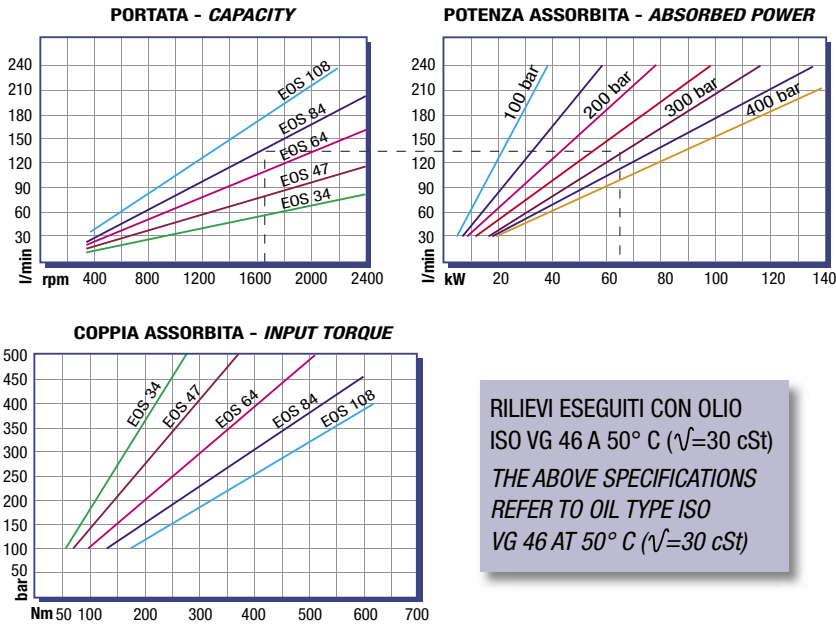

FILTRAZIONE - FILTERING

> Si raccomanda filtrazione sul ritorno (o mandata) come da tabella a lato.

La filtrazione in aspirazione è sconsigliata in quanto può generare fenomeni di cavitazione. Qualora si rendesse indispensabile, rispettare i valori limite di depressione previsti di -0,3 bar (corrispondente a 0,7 bar assoluti).

> *Filtering on return line (or outlet) recommended. Refer to the side table.*

A filter on the inlet is not recommended because of possible cavitation problems. If it is necessary, the suction pressure limit of -0,3 bar (corresponding to 0,7 absolute bar) must be respected.

Pressione Lavoro Working Press. P2	Contaminazione - Contamination		Filtro - Filter $\beta_x = 75$
	NAS 1638	ISO 4406	
≤ 200 bar	10	19/16	25 μm
< 300 bar	9	18/15	20 μm
≥ 300 bar	8	17/14	10 μm

RACCORDERIA - FITTINGS

> Avvitare sulla pompa raccordi GAS-CILINDRICO (BSP) a tenuta frontale. **NON** applicare raccordi con filettatura conica (NPT).

> *Make use of cylindric gas-fittings (BSP) with O-ring, bonded-seal on the pump. Do **NOT** use fittings with conical thread (NPT).*

NORME PER L'INSTALLAZIONE - INSTALLATION INSTRUCTIONS

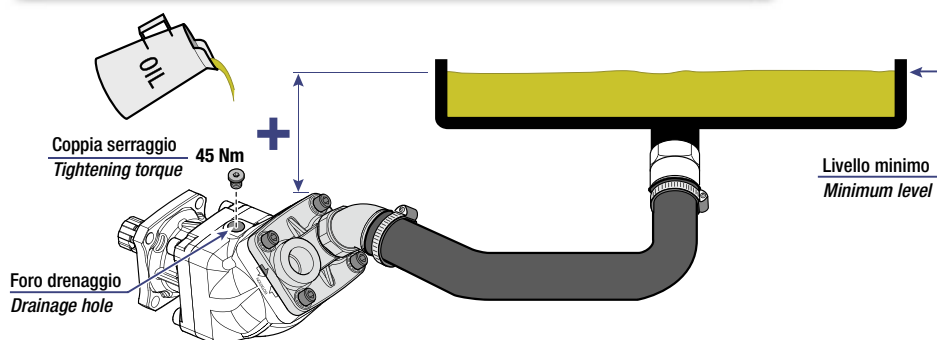

PRIMA DELL'AVVIAMENTO ASSICURARSI CHE LA POMPA SIA RIEMPITA D'OLIO O SPURGANDO L'ARIA DAL TAPPO DI DRENAGGIO O RIEMPENDOLA PREVENTIVAMENTE.

BEFORE STARTING UP MAKE SURE THAT THE PUMP IS FILLED WITH OIL, EITHER BY BLEEDING THE AIR THROUGH THE DRAINAGE HOLE OR BY FILLING THE PUMP PREVIOUSLY.

Il mancato rispetto della norma può provocare danneggiamenti alla pompa.
Failing to observe this rule may cause damages to the pump.

SENSO DI ROTAZIONE/CAMBIO ROTAZIONE - DIRECTION OF ROTATION/CHANGE OF ROTATION

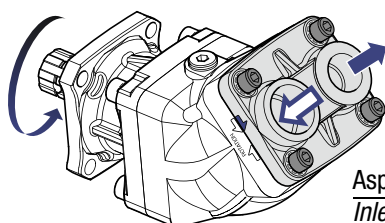

Mandata
Outlet

Aspirazione
Inlet

Determinazione senso di rotazione.

POMPA ROTAZIONE DESTRA
(P.T.O. ROTAZIONE SINISTRA)

Choosing the direction of rotation.

CLOCKWISE ROTATING PUMP
(ANTICLOCKWISE ROTATING P.T.O.)

Coppia serraggio viti 80 Nm
Tightening torque screws

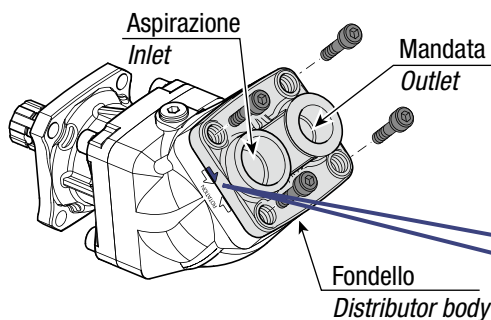

Per invertire il senso di rotazione, togliere le 4 viti e, tenendo accostato il fondello, ruotarlo di 180°. Serrare le 4 viti a 80 ± 5 Nm.

To change the direction of rotation remove the 4 screws and, keeping the distributor body close to the pump, rotate it by 180°. Tighten the 4 screws at 80 ± 5 Nm.

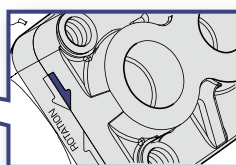

FRECCIA + TACCA =
SENSO DI ROTAZIONE

ARROW + NOTCH =
DIRECTION OF ROTATION

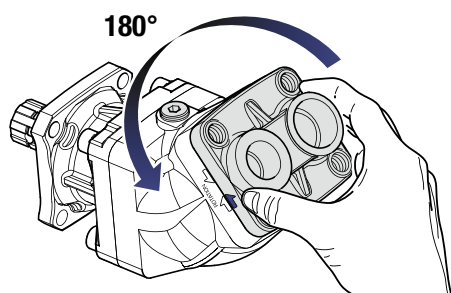

180°

ATTENZIONE:
durante l'operazione il fondello non deve mai distaccarsi dal corpo pompa per più di 2 mm.

WARNING:
during this operation the distributor body must not move away from the pump body more than 2 mm.

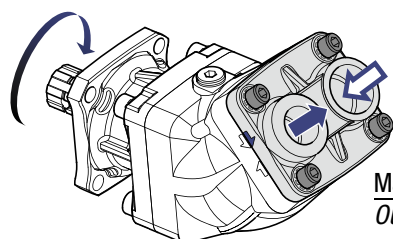

Aspirazione
Inlet

Mandata
Outlet

POMPA ROTAZIONE SINISTRA
(P.T.O. ROTAZIONE DESTRA)

ANTICLOCKWISE ROTATING PUMP
(CLOCKWISE ROTATING P.T.O.)