

SERIE ISO

3.1.2.6.

Pompa ad Ingranaggi Gear Pump

CODICE DI ORDINAZIONE - DECODING

3.1.2.6 . XXX . X . 0 . X . 0

DIN
5 4 6 2
SE

ISO 62
ISO 73
ISO 84
ISO 100
ISO 116
ISO 132
ISO 148

ALLESTIMENTI SPECIALI/SPECIAL OPTIONS
0 = NON RICHiesto/STANDARD OPTION
2 = ALBERO SUPPORTATO/BEARING GEAR
3 = ALBERO SUPPORTATO - MANDATA IN TESTA
BEARING GEAR - REAR OUTLET
7 = MANDATA IN TESTA/REAR OUTLET

ROTAZIONE/ROTATION
1 = SINISTRO/ANTICLOCKWISE
2 = DESTRO/CLOCKWISE

CILINDRATA/DISPLACEMENT

CODICE BASE/BASIC CODE

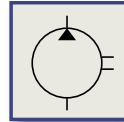

CARATTERISTICHE E DATI TECNICI - SPECIFICATIONS AND TECHNICAL DATA

TIPO TYPE	CODICE CODE	CILINDRATA DISPLACEMENT cm ³ /rev.	A mm	B mm	C ASPIRAZIONE INLET	D MANDATA OUTLET	PESO WEIGHT kg
ISO 62	3.1.2.6.062.X.0.X.0	62	122	186	1" G	3/4" G	20.4
ISO 73	3.1.2.6.073.X.0.X.0	73	126	190	1" G	3/4" G	21.1
ISO 84	3.1.2.6.084.X.0.X.0	84	130	194	1" 1/4 G	1" G	21.8
ISO 100	3.1.2.6.100.X.0.X.0	100	130	200	1" 1/4 G	1" G	22.8
ISO 116	3.1.2.6.116.X.0.X.0	116	133	206	1" 1/4 G	1" G	23.8
ISO 132	3.1.2.6.132.X.0.X.0	132	137.5	212	1" 1/2 G	1" G	24.9
ISO 148	3.1.2.6.148.X.0.X.0	148	143.5	218	1" 1/2 G	1" G	26

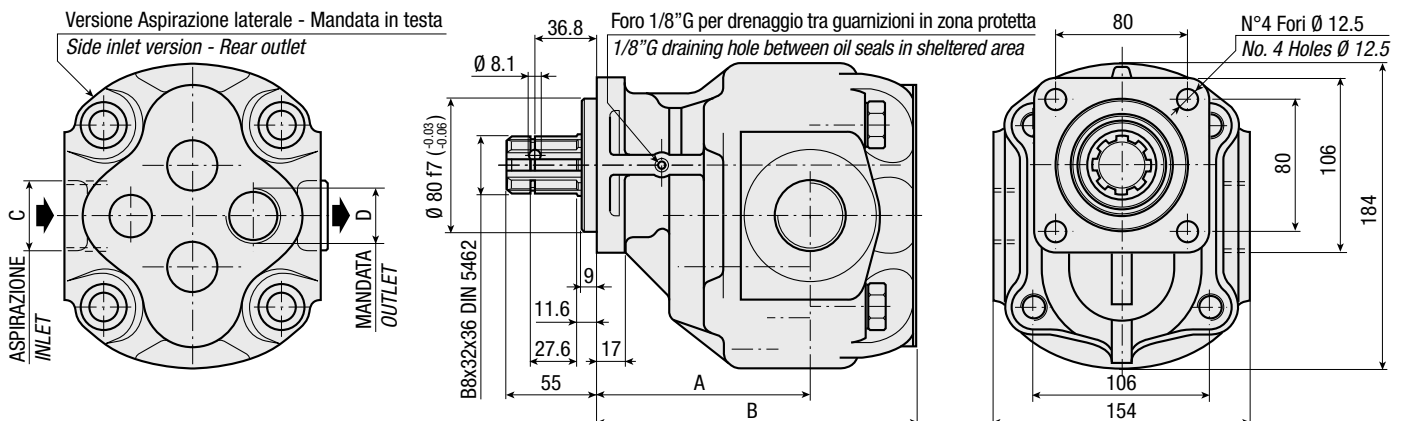

DATI TECNICI - TECHNICAL DATA

ESEMPIO CICLI LAVORO - EXAMPLE OF WORKING CYCLES

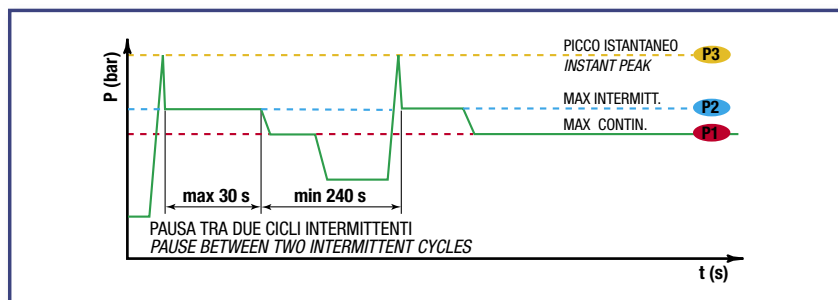

Pressione d'aspirazione: Inlet pressure:	0.7 ÷ 1.5 bar (assoluti/absolute)
Campo viscosità lavoro: Operating viscosity range:	12 ÷ 100 cSt
Temperatura fluido °C (t): Fluid temperature °C (t):	-10° + 80° C

Pressione Lavoro Working Press. P2	Contaminazione - Contamination		Filtro - Filter βx = 75
	NAS 1638	ISO 4406	
≤ 200 bar	12	21/18	40 μm
≥ 200 bar	11	20/17	25 μm

◀ **FILTRAZIONE CONSIGLIATA (ritorno o mandata)**
RECOMMENDED FILTERING (return or outlet)

TIPO - TYPE			ISO 62	ISO 73	ISO 84	ISO 100	ISO 116	ISO 132	ISO 148
Cilindrata Displacement	Vg	cm ³ /n cm ³ /rev.	62	73	84	100	116	132	148
Pressione massima continua Max continuous operating pressure	P1	bar	300	290	270	260	250	230	190
Pressione massima intermittente Max intermitt. operating pressure (max 30 s)	P2		350	320	310	290	280	270	230
Pressione massima di picco Max peak pressure (≤ 0.1 s)	P3		450	450	375	375	340	315	270
Velocità massima intermittente Max intermittent speed (P ≤ 20 bar)	n3	n/min r.p.m.	3800	3800	3500	3500	3000	3000	3000
Velocità massima continua Max continuous speed (≤ P1)	n1		2000	1800	1800	1500	1500	1500	1500
Velocità minima intermittente Min intermittent speed (≤ P2 x 0.5) (max 30 s)	n4		400	300	300	250	250	250	250

POTENZA ASSORBITA - ABSORBED POWER

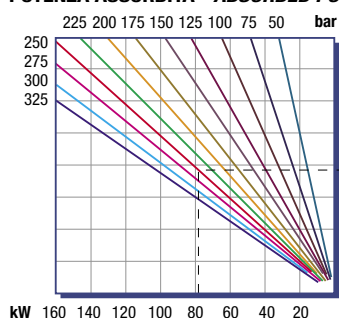

PORTATA - CAPACITY

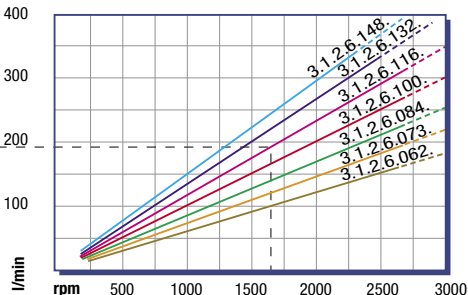

RILIEVI ESEGUITI CON OLIO
ISO VG 46 A 50° C (ν=30 cSt)
THE ABOVE SPECIFICATIONS
REFER TO OIL TYPE ISO
VG 46 AT 50° C (ν=30 cSt)

DIAGRAMMI - DIAGRAMS

RENDIMENTO VOLUMETRICO - VOLUMETRIC EFFICIENCY

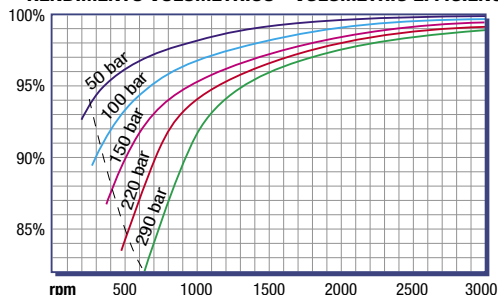

COPPIA ASSORBITA - INPUT TORQUE

